

Maytronics Remote Control Unit	1 - 4
Télécommande, Maytronics	5 - 8
Telecomando Maytronics	9 - 12
Maytronics Unidad de Control Remoto	13 - 16
Maytronics Fernbedienungseinheit	17 - 20
Maytronics afstandsbediening	21 - 24
Maytronics Unidade de Controlo Remoto	25 - 28
Пульт Дистанционного Управления	29 - 32



maytronics

Maytronics 2010 Remote Control Unit



The 2010 Remote Control Unit (RCU)

The RCU offers two operation modes - Automatic mode and Manual direction control mode. In Automatic mode, all cleaning parameters can be changed. In Manual direction mode, the Pool Cleaner direction can be controlled manually.



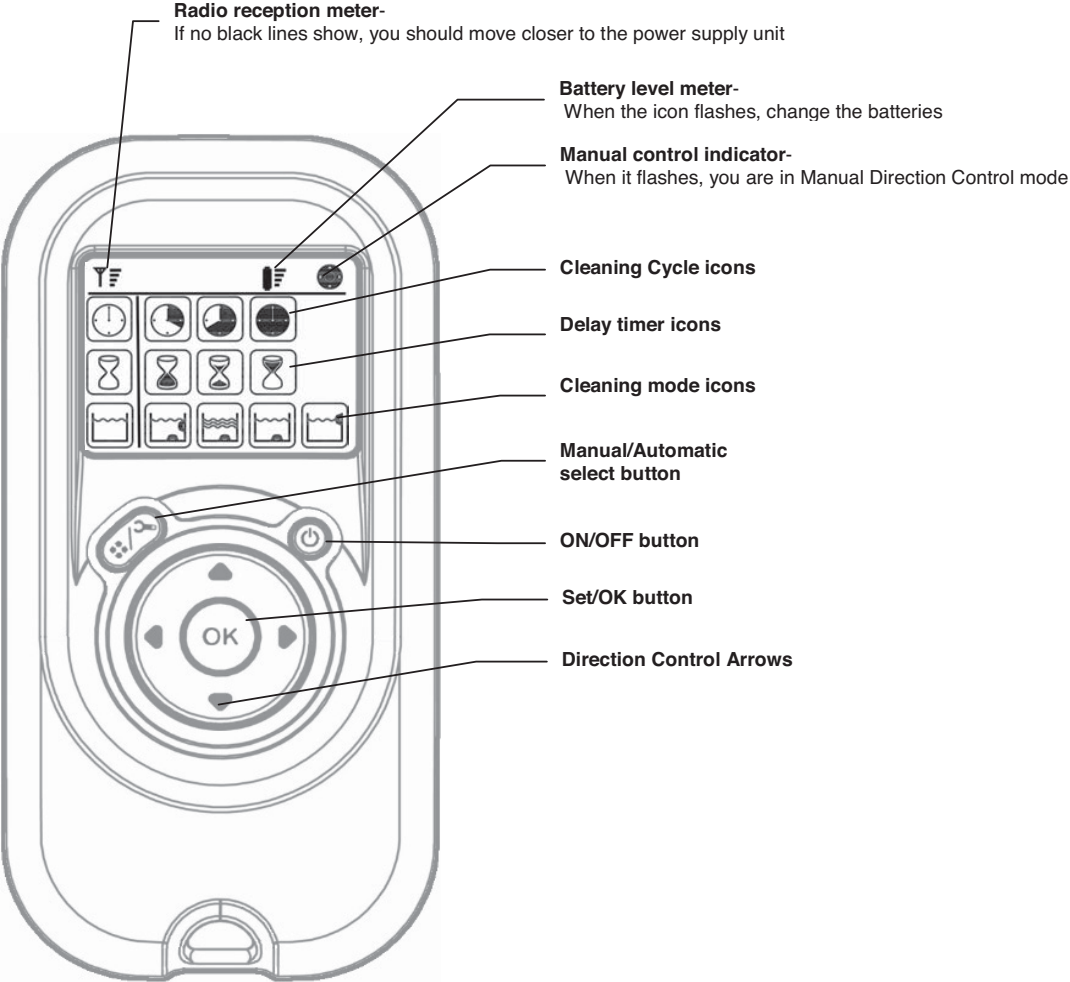









The Control Panel of the Remote Control Unit



Setting the Automatic Mode

To Change the Automatic Mode settings

First press the Manual/Automatic select button, then set according to the following table:

 <p>Cleaning cycle indicator This determines the cleaning cycle time. The RCU allows you to choose between the following options.</p>	 <p>Fast</p>	 <p>Efficient (Default setting)</p>	 <p>Extra</p>	
<p>Supreme/Pulit</p>	<p>1.5 hour cycle</p>	<p>2.5 hour cycle for everyday use</p>	<p>3.5 hour cycle</p>	
<p>Residential cleaners</p>	<p>2 hour cycle</p>	<p>3 hour cycle for everyday use</p>	<p>4 hour cycle</p>	
<p>Commercial cleaners</p>	<p>4 hour cycle</p>	<p>6 hour cycle for everyday use</p>	<p>8 hour cycle</p>	
 <p>Delay Time indicator This determines when the pool cleaner starts to work. A delay allows the dirt to settle to the bottom of the pool.</p>	 <p>Immediate start (Default setting)</p>	 <p>One Hour delay</p>	 <p>Two Hours delay</p>	
 <p>Cleaning action indicator Allowing you to choose from the following options.</p>	 <p>Standard Floor and wall cleaning. (Default setting)</p>	 <p>Ultra-clean Stronger suction and slower movement Floor and cove cleaning only.</p>	 <p>Floor only Cleans only the floor and coves.</p>	 <p>Walls Only Cleans walls and waterline only.</p>



Note:

- After 2 minutes, if no button is pressed, the Remote Control Unit will shut-down and the Pool cleaner will continue to work in the previous settings
- When the "Ultra-Clean" and "Walls Only" options finish their cycles, the RCU will return to default settings.

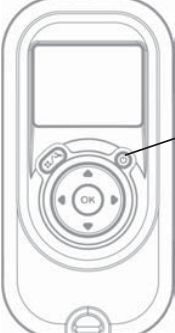
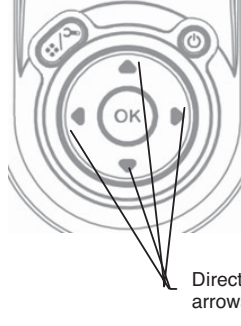
Manual Direction Control Mode

 <p>On/Off button</p>	<ol style="list-style-type: none"> 1. Press the ON/OFF button once - The RCU will start-up in Manual Direction control mode 2. To manually control the direction of the cleaner, utilise the Direction control arrows (see right) 	 <p>Direction control arrows</p>
--	---	---

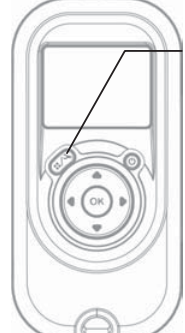
Exiting Manual Direction Control Mode and set the Automatic Mode

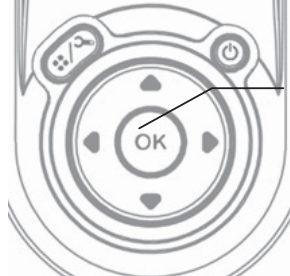
 <p>Manual/Automatic Select button</p>	<ol style="list-style-type: none"> 1. To exit the Manual direction control mode press the Manual/Automatic Selection button ONCE only 2. The Digital screen will light up and three rows of function icons will show in default mode 	
 <p>Direction control arrows</p>	<ol style="list-style-type: none"> 1. To change the parameters press the up or down arrows. To choose the parameter settings use the right or left arrows. 2. When you reach the required function press the Set/OK button 	 <p>Set/OK button</p>

Télécommande 2010 Maytronics



La télécommande 2010

La télécommande (RCU – *Remote Control Unit*) dispose de deux modes de fonctionnement – un mode de contrôle automatique et un mode de contrôle manuel de direction.

En mode automatique, tous les paramètres sont modifiables.

En mode manuel, la direction du robot nettoyeur de piscine peut être contrôlée manuellement.



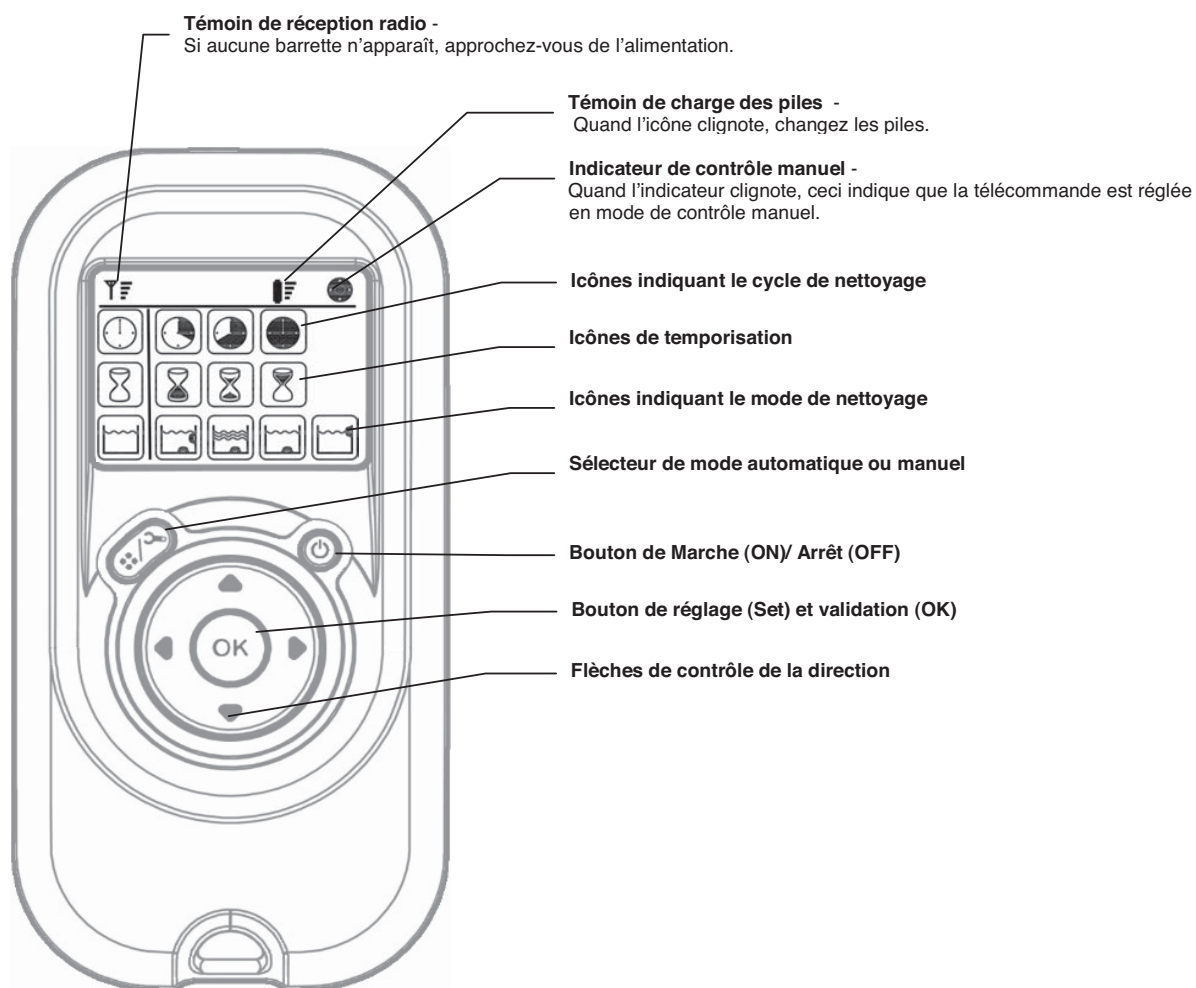









Panneau de contrôle de la télécommande



Paramétrage du mode automatique

Pour modifier les paramètres du mode automatique

Appuyez tout d'abord sur la touche Manuel / Automatique pour sélectionner le mode, ensuite réalisez les réglages selon le tableau ci-dessous :

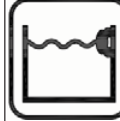
 <p>Indicateur de cycle de nettoyage Cette touche détermine la durée du cycle de nettoyage. La télécommande vous permet de choisir parmi les options suivantes.</p>	 <p>Rapide</p>	 <p>Efficace (Réglage par défaut)</p>	 <p>Extra</p>	
Supreme/Pulit	Cycle de 1h.30	Cycle de 2h.30 pour une utilisation quotidienne	Cycle de 3h.30	
Piscines résidentielles	Cycle de 2h	Cycle de 3h. pour une utilisation quotidienne	Cycle de 4h	
Piscines commerciales	Cycle de 4h	Cycle de 6h. pour une utilisation quotidienne	Cycle de 8h	
 <p>Indicateur de temporisation Cette touche détermine le moment de déclenchement du cycle par l'appareil. Un début de cycle différé (temporisé) permet de laisser les impuretés se déposer au fond de la piscine.</p>	 <p>Début de cycle immédiat (Réglage par défaut)</p>	 <p>Temporisation d'une heure</p>	 <p>Temporisation de deux heures</p>	
 <p>Indicateur du mode de nettoyage Cette touche vous permet de choisir parmi les options suivantes.</p>	 <p>Standard Nettoyage du sol et des parois (Réglage par défaut)</p>	 <p>Ultra-propre Aspiration plus puissante et mouvement plus lent. Nettoie seulement le sol et les plinthes.</p>	 <p>Sol uniquement Nettoie seulement le sol et les plinthes.</p>	 <p>Parois seulement Nettoie seulement les parois et la bordure de l'eau.</p>



Remarque :

- Au bout de 2 minutes d'inactivité des touches, la télécommande s'éteint et le robot nettoyeur poursuit le cycle entamé selon le paramétrage en cours.
- A la fin des cycles "Ultra-propre" et "Parois seulement", la télécommande récupère les réglages définis par défaut.

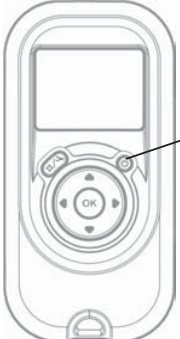
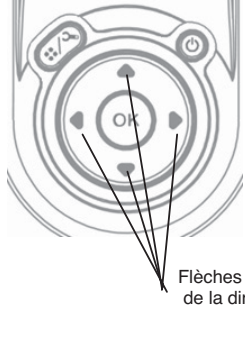
Mode de contrôle manuel de la direction

 <p>Bouton Marche/ Arrêt</p>	<ol style="list-style-type: none">1. Appuyez une fois sur le bouton Marche / Arrêt (ON/OFF) - La télécommande démarre en mode de contrôle manuel de la direction2. Pour contrôler manuellement la direction du robot nettoyeur, utilisez les touches directionnelles selon le sens des flèches (voir schéma de droite)	 <p>Flèches de contrôle de la direction</p>
---	---	---

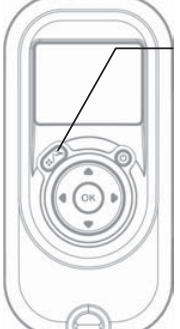
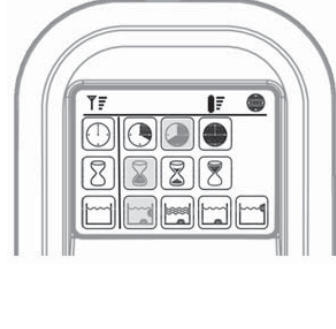
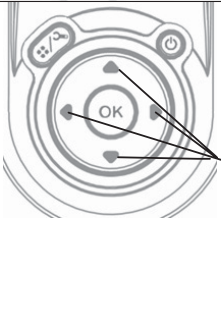
Sortie du mode de contrôle manuel et Réglage du mode automatique

 <p>Sélecteur de mode Manuel/ Automatique</p>	<ol style="list-style-type: none">1. Pour quitter le mode de contrôle manuel de la direction, appuyez UNE SEULE fois sur le sélecteur de mode Manuel/ Automatique2. L'afficheur numérique s'allume et trois lignes de boutons fonctionnels s'affichent avec le paramétrage défini par défaut	
 <p>Flèches de contrôle de la direction</p>	<ol style="list-style-type: none">1. Modifiez les paramètres à l'aide des flèches orientées vers le haut ou vers le bas. Pour sélectionner les divers réglages, utilisez les flèches orientées vers la droite ou vers la gauche2. Dès que vous atteignez la fonction voulue, il vous suffit d'appuyer sur le bouton Réglage / Validation (Set/OK)	 <p>Bouton Réglage/ Validation</p>

Telecomando Maytronics 2010



Telecomando Maytronics 2010 (RCU)

Il telecomando offre due modalità operative – la modalità automatica e la modalità di controllo manuale della direzione.

In modalità automatica, tutti i parametri relativi alla pulizia possono essere modificati.

In modalità direzione manuale, la direzione del robot di pulizia della piscina può essere controllata manualmente.



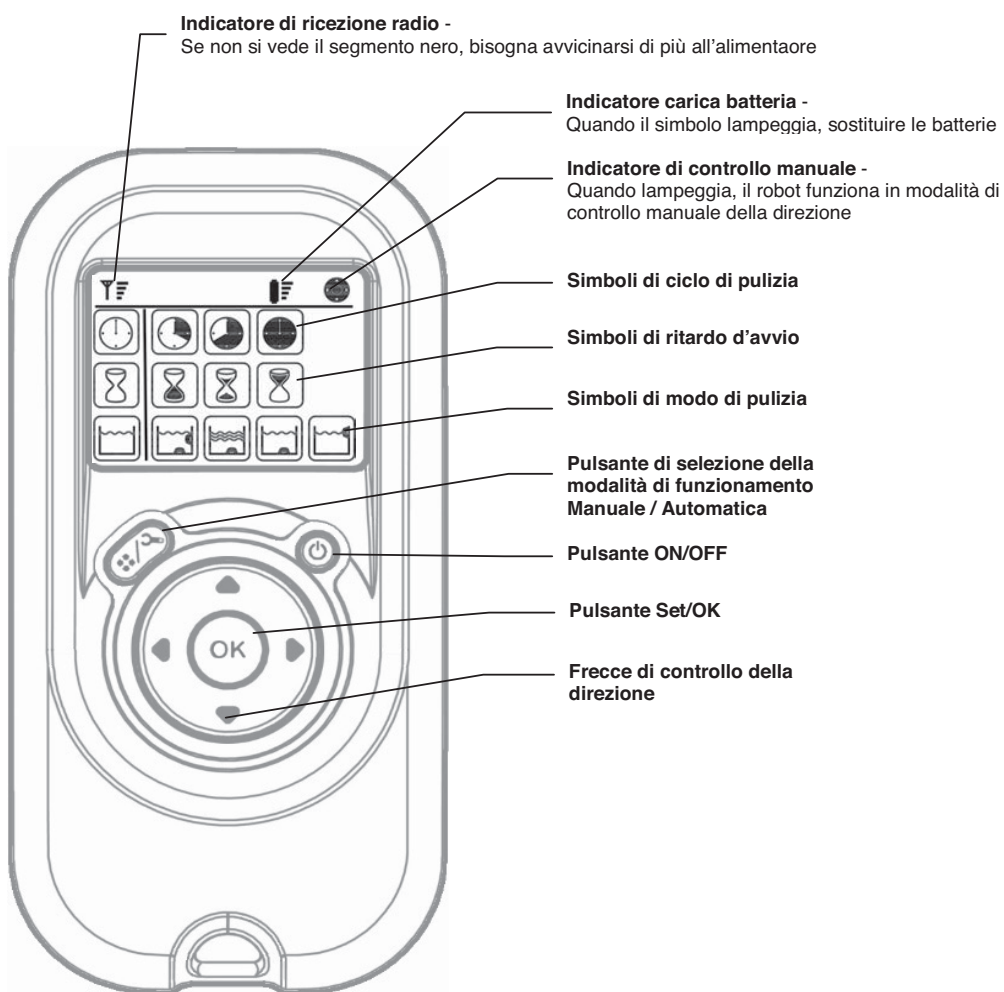









Il pannello di controllo del telecomando



Impostazione della modalità automatica

Come modificare le impostazioni in modalità automatica

Premere prima il pulsante di selezione della modalità Manuale / Automatica, poi eseguire le impostazioni secondo la tabella che segue:

 <p>Indicatore del ciclo di pulizia Questo determina la durata del ciclo di pulizia. Il telecomando consente di scegliere tra le opzioni seguenti.</p>	 <p>Veloce</p>	 <p>Efficiente (Impostazione predefinita)</p>	 <p>Extra</p>	
<p>Supreme/Pulit</p>	<p>Ciclo della durata di 1,5 ore</p>	<p>Ciclo della durata di 2,5 ore per uso quotidiano</p>	<p>Ciclo della durata di 3,5 ore</p>	
<p>Piscine residenziali</p>	<p>Ciclo della durata di 2 ore</p>	<p>Ciclo della durata di 3 ore per uso quotidiano</p>	<p>Ciclo della durata di 4 ore</p>	
<p>Piscine commerciali</p>	<p>Ciclo della durata di 4 ore</p>	<p>Ciclo della durata di 6 ore per uso quotidiano</p>	<p>Ciclo della durata di 8 ore</p>	
 <p>Indicatore del tempo in cui l'avvio è posticipato Questo stabilisce quando il robot per la pulizia della piscina viene attivato. L'avvio posticipato consente allo sporco di depositarsi sul fondo della piscina.</p>	 <p>Avvio immediato (Impostazione predefinita)</p>	 <p>Un'ora di ritardo</p>	 <p>Due ore di ritardo</p>	
 <p>Indicatore del modo di pulizia Consente di scegliere tra i seguenti modi di pulizia.</p>	 <p>Standard Pulizia di fondale e pareti (Impostazione predefinita).</p>	 <p>Ultra-pulito Maggiore suzione e movimento più lento Pulizia di soli fondale ed angoli.</p>	 <p>Solo fondale Pulizia di soli fondale ed angoli.</p>	 <p>Solo pareti Pulizia di sole pareti e linea di livello dell'acqua.</p>



Nota:

- Dopo 2 minuti, se non viene premuto alcun pulsante, il telecomando si spegne ed il robot continua a funzionare in base alle impostazioni selezionate in precedenza
- Quando termina il ciclo nei modi di pulizia "Ultra-pulito" e "Solo pareti", il telecomando ritorna alle impostazioni predefinite.

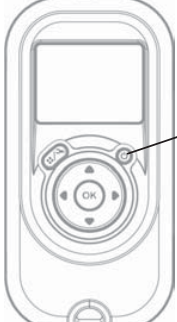
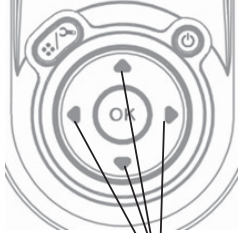
Modalità di controllo manuale della direzione

 <p>Pulsante On/Off</p>	<ol style="list-style-type: none">1. Premere una volta il pulsante ON/OFF - Il telecomando avvia il robot in modalità di controllo manuale della direzione2. Per controllare manualmente la direzione del robot, utilizzare le frecce di controllo della direzione (come illustrato nella figura a destra)	 <p>Frecce per il controllo della direzione</p>
--	---	---

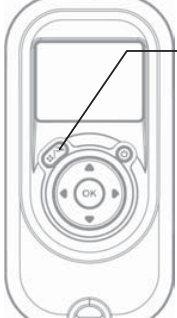
Impostazione della modalità automatica di funzionamento al posto della modalità di controllo manuale della direzione

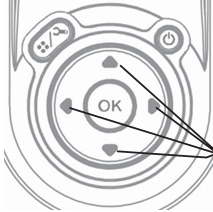
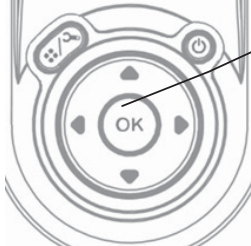
 <p>Pulsante di selezione della modalità Manuale / Automatica</p>	<ol style="list-style-type: none">1. Per uscire dalla modalità di controllo manuale della direzione, premere UNA SOLA VOLTA il pulsante di selezione della modalità Manuale / Automatica2. Il quadrante digitale si illumina ed appaiono tre file di simboli in modalità predefinita	
 <p>Frecce di controllo della direzione</p>	<ol style="list-style-type: none">1. Per modificare i parametri premere le frecce in su o in giù. Per scegliere le impostazioni dei parametri usare le frecce a destra ed a sinistra.2. Una volta raggiunta la funzione desiderata, premere il pulsante Set/OK	 <p>Pulsante Set/OK</p>

Maytronics 2010 Unidad de Control Remoto



La Unidad de Control Remoto de 2010 (RCU)

La RCU ofrece dos modos de operación – Modo Automático y Modo Manual de Control de dirección.
En el modo Automático, todos los parámetros de limpieza pueden ser modificados.
En el modo Manual de dirección, la dirección del Limpiador de Piscinas puede ser controlada manualmente.



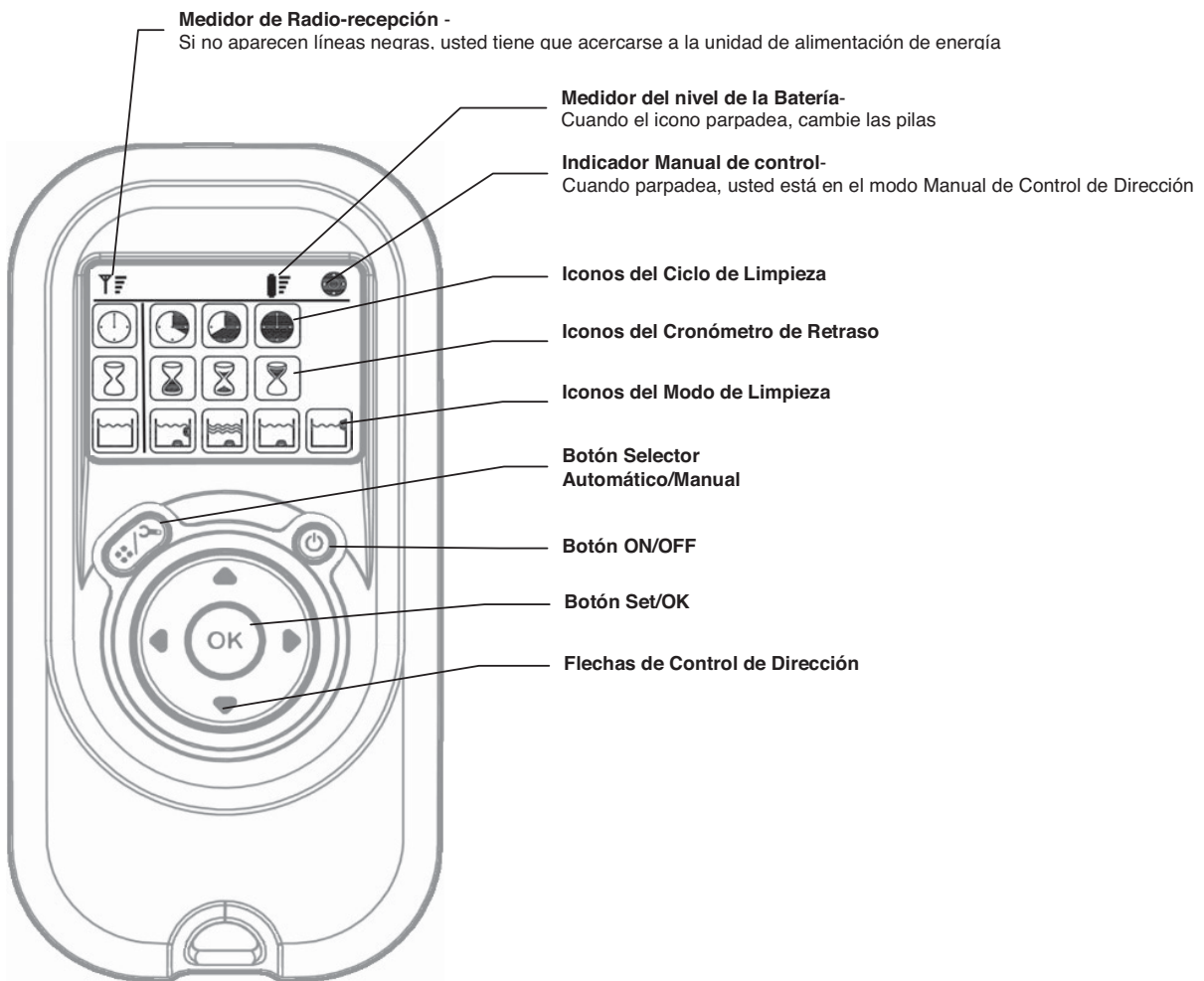









El Panel de Control de la Unidad de Control Remoto



Configurando el Modo Automático

Para Modificar la Configuración del Modo Automático

Primero presione el botón de selección Manual/Automático, después configure según la tabla siguiente:

				
Indicador del Ciclo de Limpieza Determina el tiempo del ciclo de limpieza. La RCU permite que usted elija entre las siguientes opciones.	Rápido	Eficiente (Configuración predeterminada)	Extra	
Supreme/Pulit	Ciclo de 1.5 horas	Ciclos de 2.5 horas para uso diario	Ciclo de 3.5 horas	
Piscinas residenciales	Ciclo de 2 horas	Ciclos de 3 horas para uso diario	Ciclo de 4 horas	
Piscinas comerciales	Ciclo de 4 horas	Ciclos de 6 horas para uso diario	Ciclo de 8 horas	
				
Indicador del Tiempo de Retraso Determina cuando el limpiador de piscina empieza a operar. Un retraso permite que la suciedad se establezca en el fondo de la piscina.	Inicio Inmediato (Configuración predeterminada)	Retraso de Una Hora	Retraso de Dos Horas	
				
Indicador de la Acción de Limpieza Permite que usted elija entre las siguientes opciones.	Standard (Configuración predeterminada) Limpieza de piso y pared.	Ultra-limpio Más succión y movimiento más lento. Limpia solamente el piso y los rincones.	Solamente el Piso Limpia solamente el piso y los rincones.	Solamente las Paredes Limpia solamente las paredes y la línea de agua.

Nota:

- Pasados 2 minutos, si ninguno de los botones fue presionado, la Unidad de Control Remoto se cierra y el Limpiador de Piscina continuará operando en la configuración anterior.
- Cuando las opciones "Ultra-Limpio" y "Solamente Paredes" concluyen sus ciclos, la RCU retornará a la configuración preestablecida.

Modo Manual de Control de Dirección

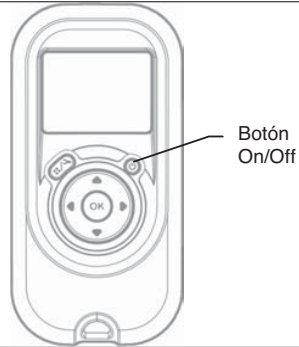

1. Presione el botón ON/OFF una vez - La RCU iniciará en el modo Manual de Control de Dirección
2. Para controlar manualmente la dirección del limpiador, use las flechas de control de dirección (ver a la derecha)

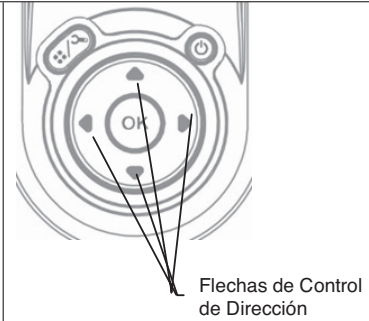

Salir del Modo Manual de Control de Dirección y configurar el Modo Automático

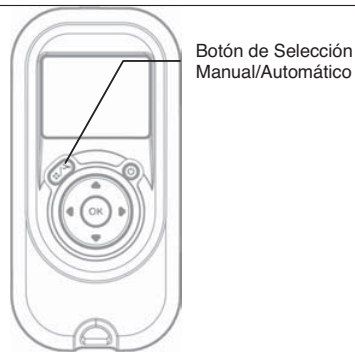

1. Para salir del modo Manual de Control de Dirección, presione el botón de Selección Manual/Automático apenas UNA VEZ
2. La pantalla digital se iluminará y tres líneas de iconos de función aparecerán en el modo predeterminado

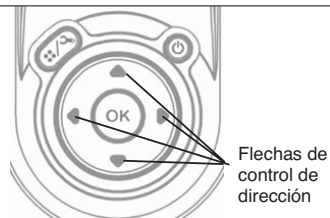
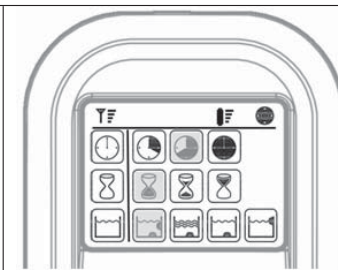

1. Para modificar los parámetros presione las flechas para arriba y para abajo. Para elegir la configuración de los parámetros, use las flechas de la derecha o de la izquierda
2. Cuando llegar a la función deseada, presione el botón Set/OK

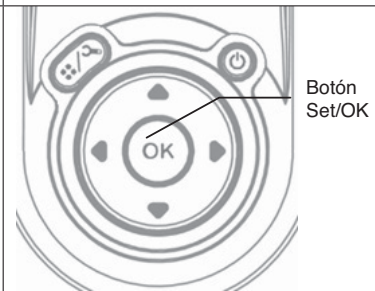

Maytronics 2010 Fernbedienungseinheit



Die 2010 Fernbedienungseinheit (RCU)

Die Fernbedienungseinheit bietet Ihnen zwei Betriebsmoden – den automatischen Modus und den manuellen Steuermodus.

Im automatischen Modus können alle Reinigungsparameter geändert werden.

Im manuellen Steuermodus kann die Richtung des Schwimmbadreinigers manuell gesteuert werden.



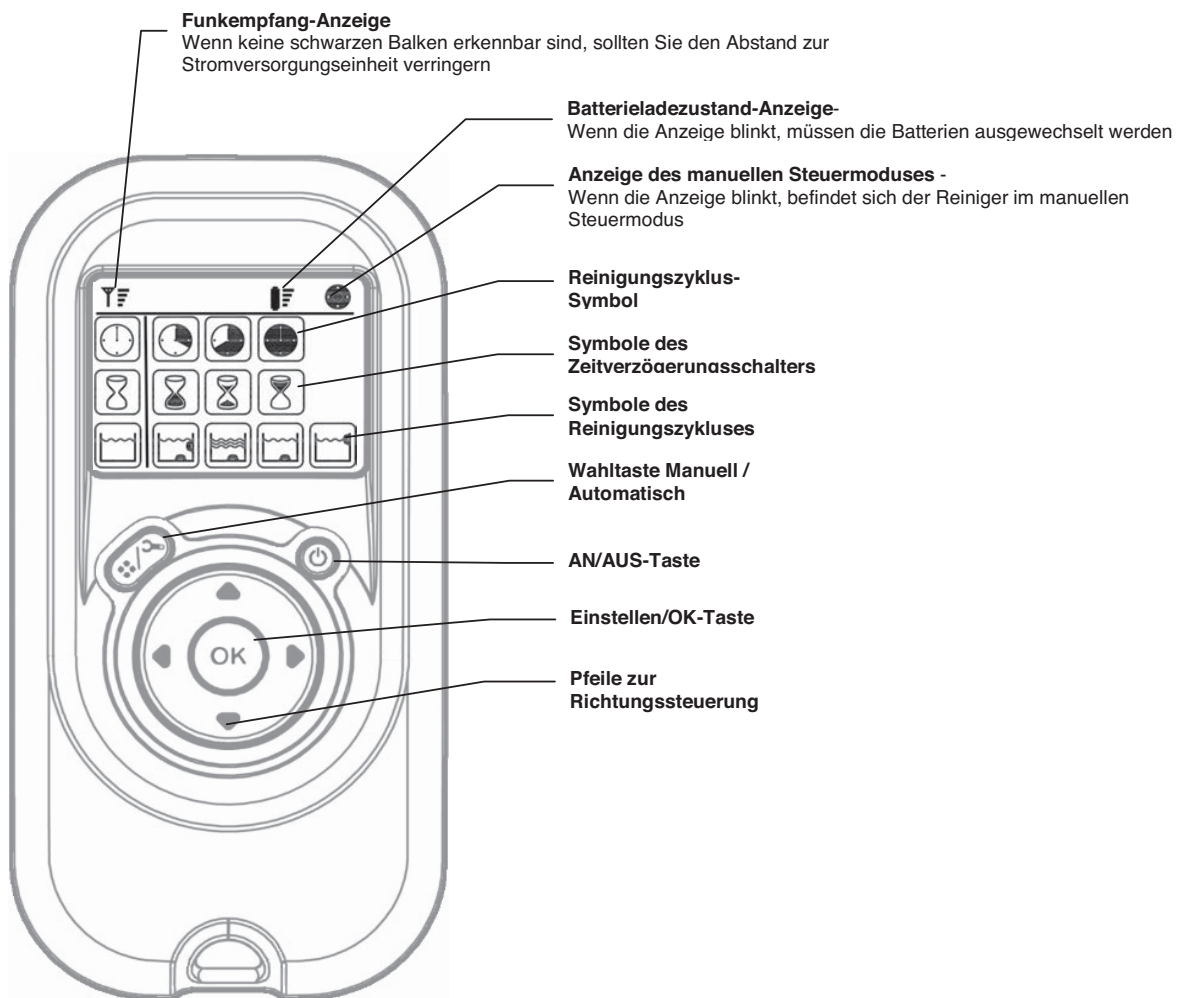









Das Bedienfeld der Fernbedienungseinheit



Einstellen des automatischen Moduses

So ändern Sie die Einstellungen des automatischen Moduses



Zuerst müssen Sie auf die Wahltaaste Manuell/Automatisch drücken und dann den Modus gemäss folgender Tabelle einstellen:

 <p>Reinigungsmodus-Anzeige Hier können Sie die Reinigungszyklus-Zeit einstellen. Sie können mit Hilfe der RCU zwischen folgenden Optionen wählen.</p>	 <p>Schnell</p>	 <p>Effizient (Standardeinstellung)</p>	 <p>Extra</p>	
<p>Supreme/Pulit</p>	<p>1,5 Stunden - Zyklus</p>	<p>2,5 Stunden – Zyklus für tagtägliche Benutzung</p>	<p>3,5 Stunden – Zyklus</p>	
<p>Private Schwimmbecken</p>	<p>2 Stunden - Zyklus</p>	<p>3 Stunden – Zyklus für tagtägliche Benutzung</p>	<p>4 Stunden – Zyklus</p>	
<p>Gewerbliche Schwimmbecken</p>	<p>4 Stunden - Zyklus</p>	<p>6 Stunden – Zyklus für tagtägliche Benutzung</p>	<p>8 Stunden – Zyklus</p>	
 <p>Zeitverzögerungs-Anzeige Hier können Sie festlegen, wann der Schwimmbad-Reiniger mit der Reinigung beginnt. Eine Verzögerung ermöglicht es dem Schmutz, sich auf dem Beckenboden abzusetzen.</p>	 <p>Sofortiger Start (Standard-Einstellung)</p>	 <p>Verzögerung von einer Stunde</p>	 <p>Verzögerung von zwei Stunden</p>	
 <p>Anzeige der Reinigungs-Aktivität Ermöglicht Ihnen, eine der folgenden Optionen zu wählen.</p>	 <p>Standard Boden- und Wandreinigung (Standard-Einstellung)</p>	 <p>Ultra-Sauber Stärkere Saugleistung und langsamere Bewegung. Nur für die Reinigung des Bodens und der Wölbung.</p>	 <p>Nur Boden Reinigt nur den Beckenboden und die Wölbungen.</p>	 <p>Nur Wände Reinigt die Wände und die Wasserlinie.</p>

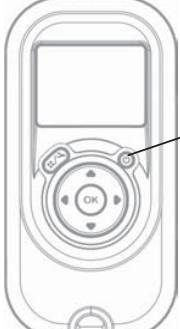

Hinweis:

- Wenn nach 2 Minuten noch keine Taste gedrückt worden ist, schaltet sich die Fernbedienungseinheit ab und der Schwimmbadreiniger arbeitet weiter mit den vorher eingestellten Einstellungen.
- Wenn die Optionen "Ultra-Sauber" und "Nur Wände" ihren Zyklus beendet haben, kehrt die Fernbedienungseinheit zu den Standardeinstellungen zurück.

Manueller Steuermodus

 <p>An-/Aus-Taste</p>	<ol style="list-style-type: none"> 1. Drücken Sie einmal auf die AN-/Aus-Taste – die Fernbedienungseinheit schaltet daraufhin in den manuellen Steuermodus. 2. Um die Richtung des Reinigers manuell kontrollieren zu können, müssen Sie die Richtungspfeile benutzen (siehe rechts). 	 <p>Richtungspfeile</p>
--	---	--

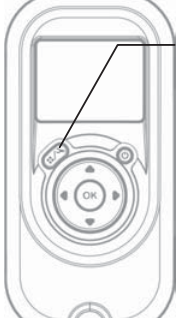
Verlassen des manuellen Steuermodus und Einstellen des automatischen Moduses

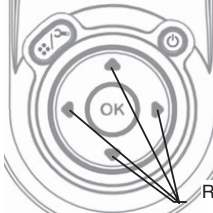
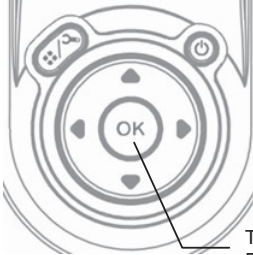
 <p>Wahltaste manuell / automatisch</p>	<ol style="list-style-type: none"> 1. Drücken Sie einmal auf die Wahl taste Manuell/Automatisch, um den manuellen Steuermodus zu verlassen. 2. Daraufhin leuchtet der digitale Bildschirm auf und zeigt drei Reihen von Funktionssymbolen in der Standardeinstellung. 	
 <p>Richtungs-pfeile</p>	<ol style="list-style-type: none"> 1. Um die Parameter zu ändern, drücken Sie auf die Pfeile nach oben oder unten. Jetzt können Sie die Parametereinstellungen mit Hilfe der Pfeile nach rechts oder links auswählen. 2. Sobald Sie die gewünschte Funktion erreicht haben, drücken Sie auf die Taste Einstellen/OK. 	 <p>Taste Einstellen/OK</p>

Maytronics 2010 afstandsbediening



De 2010 afstandsbediening (RCU)

De RCU heeft twee werkmodi – de Automatische modus en de Handmatige werkriching bedieningsmodus.

In de Automatische modus kunnen alle schoonmaakparameters worden veranderd.

In de Handmatige werkriching bedieningsmodus kan de schoonmaakrichting van het zwembad handmatig worden bestuurd.



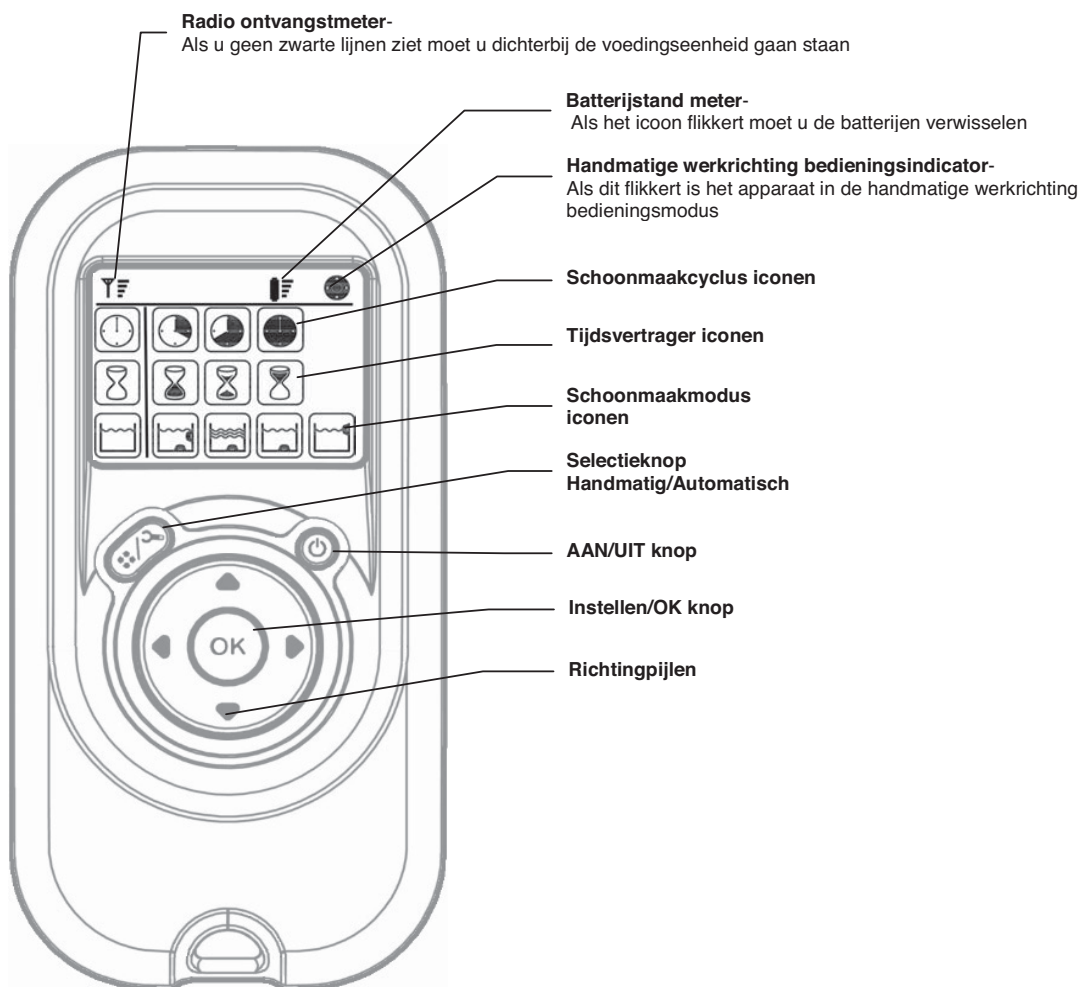









Het controlepaneel van de afstandsbediening



De automatische modus instellen

De automatische modus instellingen veranderen

Druk eerst op de selectieknop Handmatig/Automatisch en stel vervolgens de volgende tabel in:

				
Schoonmaakcyclus indicator Hiermee wordt de schoonmaakcyclus tijd ingesteld. Met de RCU kunt u tussen de volgende opties kiezen.	Snel	Efficiënt (Standaard instelling)	Extra	
Supreme/Pulit	1.5 uur cyclus	2.5 uur cyclus voor dagelijks gebruik	3.5 uur cyclus	
Residentieel poolreinigers	2 uur cyclus	3 uur cyclus voor dagelijks gebruik	4 uur cyclus	
Commerciële poolreinigers	4 uur cyclus	6 uur cyclus voor dagelijks gebruik	8 uur cyclus	
				
Vertragingstijd indicator Dit bepaalt wanneer de zwembadschoonmaker gaat werken. Met vertraging kan het vuil op de vloer van het zwembad komen.	Gelijk beginnen (Standaard instelling)	Een uur vertraging	Twee uur vertraging	
				
Schoonmaakactie indicator Hiermee kunt u kiezen uit de volgende opties.	Standaard Vloer en muren schoonmaken. (Standaard instelling)	Ultraschoon Krachtiger zuigen met langzamere beweging. Alleen om de vloer en nissen schoon te maken.	Alleen vloer Maakt alleen de vloer en nissen schoon.	Alleen muren Maakt alleen de muren en wateroppervlak schoon.



Opmerking:

- Als er na 2 minuten niet op een knop wordt gedrukt gaat de afstandsbediening uit en werkt de zwembadschoonmaker volgens de eerder ingestelde instellingen
- Als de cyclusopties "Ultraschoon" en "Alleen muren" voltooid zijn gaat de RCU terug naar de Standaard instellingen.

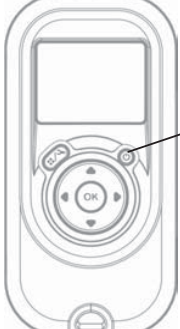
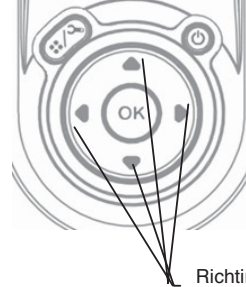
Handmatige werkriching bedieningsmodus

 <p>Aan/Uit knop</p>	<ol style="list-style-type: none"> 1. Druk een keer op de AAN/UIT knop - de RCU begint in de Handmatige werkriching bedieningsmodus 2. Om de richting van de schoonmaker handmatig te bedienen gebruikt u de richtingpijltjes (Zie rechts) 	 <p>Richtingpijltjes</p>
---	--	--

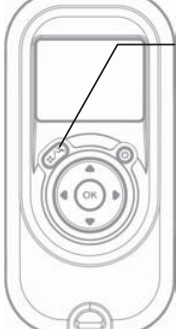
Van de Handmatige werkriching bedieningsmodus naar de Automatische modus

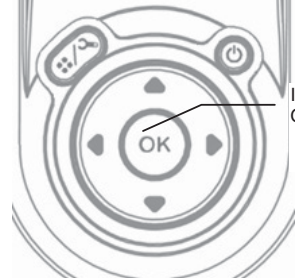
 <p>Selectiekноп Handmatig/Automatisch</p>	<ol style="list-style-type: none"> 1. Om uit de Handmatige werkriching bedieningsmodus te gaan drukt u maar EEN KEER op de selectiekноп Handmatig/Automatisch 2. Het digitale scherm licht op en u ziet drie rijen functie iconen in de standaard modus 	
 <p>Richtingpijltjes</p>	<ol style="list-style-type: none"> 1. Om de parameters te veranderen drukt u op de pijltjes naar boven of beneden. Om de parameter instellingen te kiezen gebruikt u de rechter of linker pijltjes 2. Als u de vereiste functie heeft bereikt drukt u op de Instellen/OK knop 	 <p>Instellen/OK knop</p>

Maytronics 2010 Unidade de Controlo Remoto



A Unidade de Controlo Remoto de 2010 (RCU)

A RCU oferece dois modos de operação – Modo Automático e Modo Manual de Controlo de direcção. No modo Automático, todos os parâmetros de limpeza podem ser modificados. No modo Manual de direcção, a direcção do Limpador de Piscinas pode ser controlada manualmente.



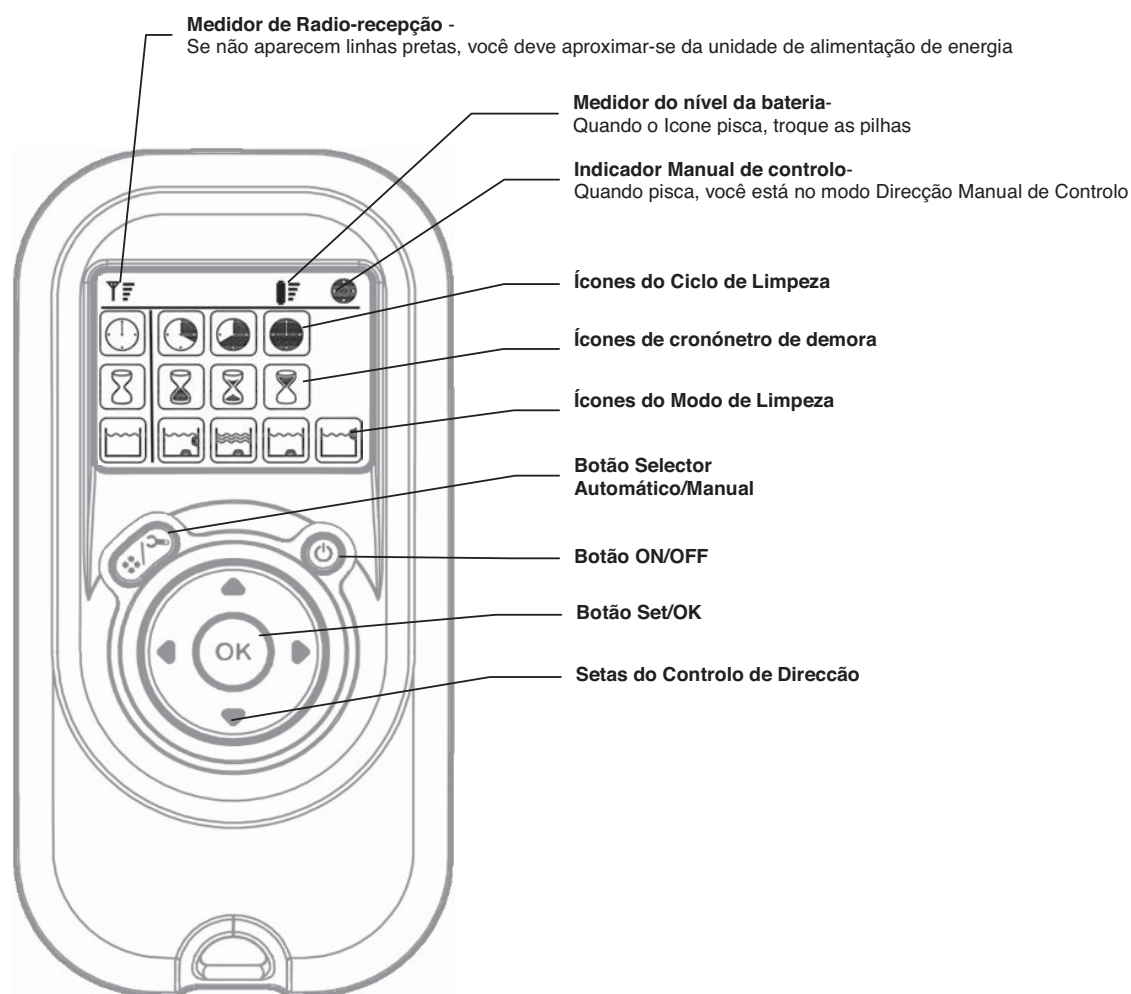









O Painel de Controlo da Unidade de Controlo Remoto



Configurando o Modo Automático

Para Modificar a Configuração do Modo Automático

Primeiro pressione o botão de selecção Manual/Automático, depois configure de acordo com a tabela seguinte:

				
Indicador do Ciclo de Limpeza Este determina o tempo do ciclo de limpeza. A RCU permite escolher entre as opções seguintes.	Rápido	Eficiente (Configuração pré-determinada)	Extra	
Supreme/Pulit	Ciclo de 1,5 horas	Ciclos de 2,5 horas para uso diário	Ciclo de 3,5 horas	
Limpadores residenciais	Ciclo de 2 horas	Ciclos de 3 horas para uso diário	Ciclo de 4 horas	
Limpadores comerciais	Ciclo de 4 horas	Ciclos de 6 horas para uso diário	Ciclo de 8 horas	
				
Indicador do Tempo de Início Retardado Este determina quando o limpador de piscina começa a operar. Um início retardado permite que a sujidade se deposite no fundo da piscina.	Início imediato (Configuração pré-determinada)	Início Retardado em Uma Hora	Início Retardado em Duas Horas	
				
Indicador da Acção de Limpeza Permite a escolha entre as opções seguintes.	Padrão Limpeza de piso e parede. (Configuração pré-determinada)	Ultra-limpo Maior sucção e movimento mais lento. Limpa somente o piso e a cavidade.	Somente Piso Limpa somente o piso e as cavidades.	Somente Paredes Limpa somente as paredes e a linha de água.

Nota:

- Depois de decorridos 2 minutos, se nenhum botão for pressionado, a Unidade de Controlo Remoto desliga-se e o Limpador de Piscina continua a operar na configuração anterior.
- Quando as opções "Ultra-Limpo" e "Somente Paredes" concluem os seus ciclos, a RCU retorna à configuração pré-estabelecida.

Modo Manual de Controlo de Direcção

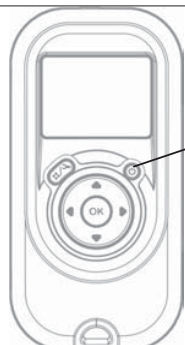
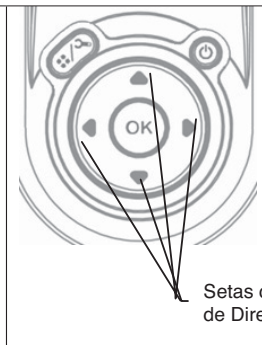
 <p>Botão On/Off</p>	<ol style="list-style-type: none">1. Pressione o botão ON/OFF uma vez - A RCU iniciará no modo Manual de Controlo de Direcção2. Para controlar manualmente a direcção do limpador, use as setas de controlo de direcção (ver à direita)	 <p>Setas de Controlo de Direcção</p>
---	--	---

Sair do Modo Manual de Controlo de Direcção e Configurar o Modo Automático

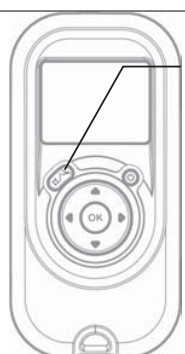
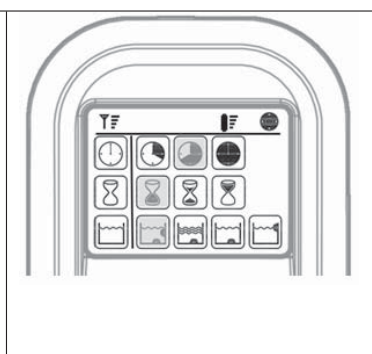
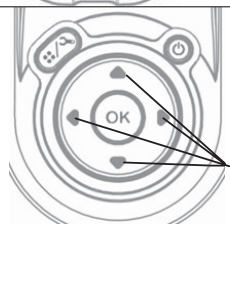
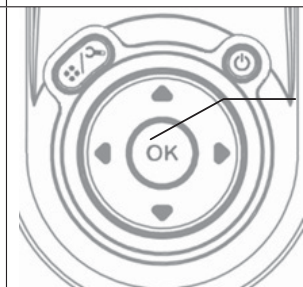
 <p>Botão de Selecção Manual/Automático</p>	<ol style="list-style-type: none">1. Para sair do modo Manual de controlo de direcção, pressione o botão de Selecção Manual/Automático apenas UMA VEZ2. O ecrã digital ilumina-se e três linhas de ícones de função aparecem no modo pré-determinado	
 <p>Setas de controlo de direcção</p>	<ol style="list-style-type: none">1. Para modificar os parâmetros pressione as setas para cima e para baixo. Para escolher a configuração dos parâmetros, use as setas da direita ou da esquerda2. Quando obtiver a função desejada, pressione o botão Set/OK	 <p>Botão Set/OK</p>

Пульт Дистанционного Управления 2010



Пульт Дистанционного Управления (ПДУ) 2010

ПДУ предоставляет два вида режима управления - Автоматический и ручной.
В автоматическом режиме работы можно изменять все параметры чистки.
В ручном режиме работы, движение робота управляется в ручную.



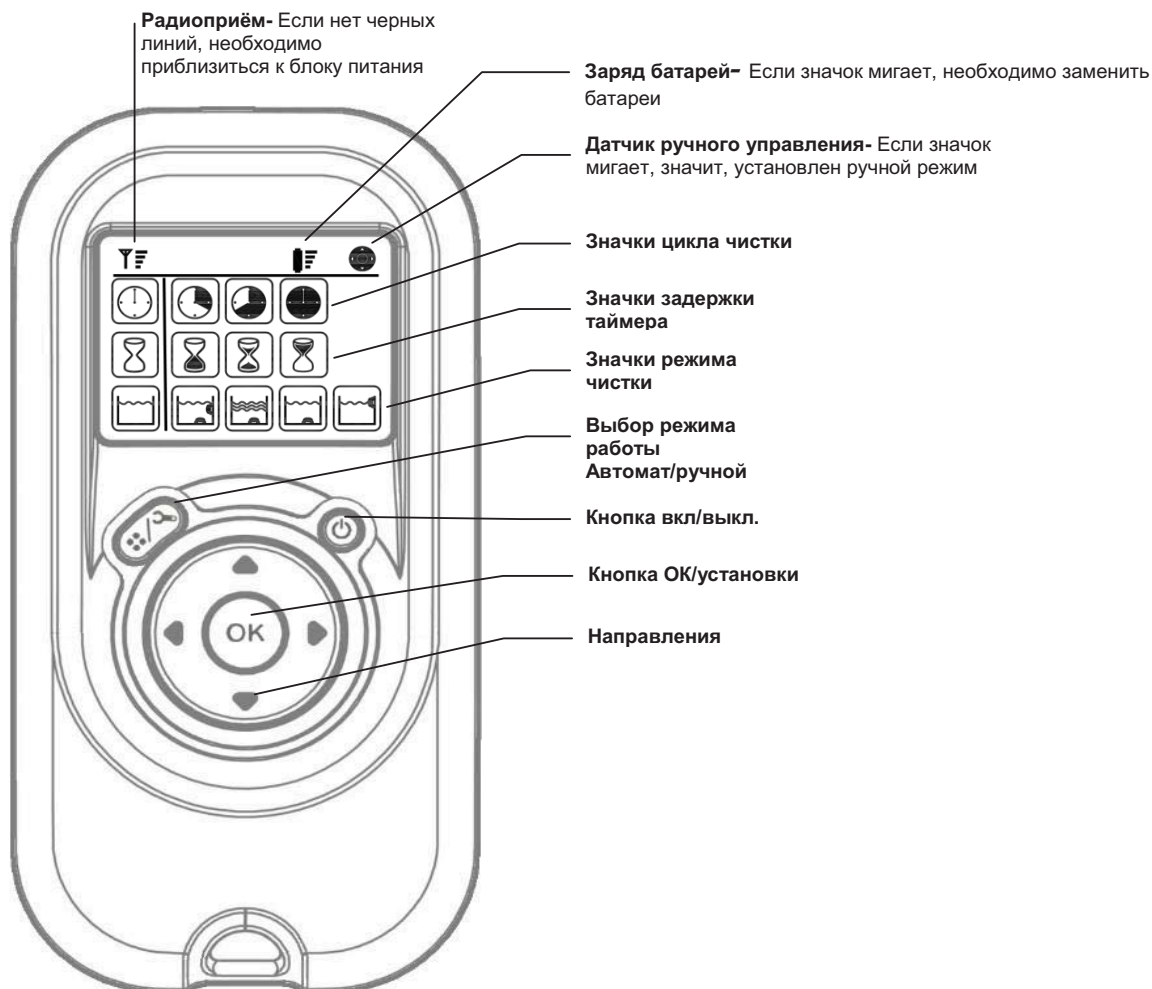









Панель управления ПДУ



Установка автоматического режима

Для изменения установок автоматического режима

Сначала нажми на кнопку выбора режима, затем выбери необходимые установки в соответствии с таблицей

 <p>Датчик цикла чистки Определение цикла чистки. ПДУ позволяет выбрать один из следующих вариантов</p>	 <p>Быстрый</p>	 <p>Эффективный (Базовая установка)</p>	 <p>Экстра</p>	
<p>Supreme/Pulit</p>	<p>1.5 часа</p>	<p>2.5 часа для ежедневного использования</p>	<p>3.5 часа</p>	
<p>для частных бассейнов</p>	<p>2 часа</p>	<p>3 часа для ежедневного использования</p>	<p>4 часа</p>	
<p>для общественных бассейнов</p>	<p>4 часа</p>	<p>6 часа для ежедневного использования</p>	<p>8 часа</p>	
 <p>Датчик задержки таймера Определение, когда робот начал работу. Задержка позволяет мусору осесть на дно бассейна</p>	 <p>Немедленное начало (Базовая установка)</p>	 <p>Один час задержки</p>	 <p>Два часа задержки</p>	
 <p>Датчик действий Позволяет выбрать один из следующих вариантов</p>	 <p>Стандарт Чистка дна и стен (Базовая установка)</p>	 <p>Усиленная чистка Усиленное всасывание и медленное движение Чистка дна и стыков</p>	 <p>Только дно Чистка дна и стыков</p>	 <p>Только стены Чистит только стены и линию воды</p>
<p>Заметка:</p> <ul style="list-style-type: none"> • После 2 минут, если не нажата кнопка, ПДУ выключится, и робот будет продолжать работать в предыдущих настройках. • Когда циклы работы, с выбранными опциями "Усиленной чистки" и "Только стены", закончатся, ПДУ вернётся к базисным установкам. 				

Ручное управление робота

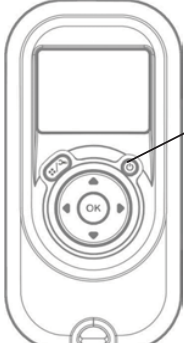
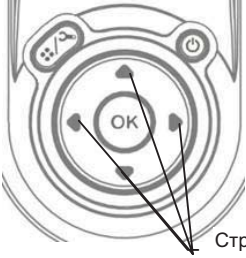
 <p>Кнопка вкл./выкл.</p>	<ol style="list-style-type: none"> 1. Нажми кнопку вкл./выкл., один раз - ПДУ запустится в ручном режиме управления 2. Для ручного управления используй стрелки направления движения - см. справа 	 <p>Стрелки направления движения</p>
--	---	---

Выход из ручного режима и установка автоматического режима

 <p>Кнопка выбора режима</p>	<ol style="list-style-type: none"> 1. Для выхода из Ручного режима работы, необходимо нажать один раз на кнопку Выбора режима. 2. Цифровой экран загорится и в трёх рядах функций высветятся значки вазовых установок 	
 <p>Стрелки направления движения</p>	<ol style="list-style-type: none"> 1. Для изменения параметров нажми на стрелки вверх/вниз Для выбора параметра нажми на стрелки вправо/влево 2. Для установки желаемой функции нажми кнопку ОК/установка 	 <p>Кнопка установки/ОК</p>